

SAMPLING DEVICES

KSSD

**GENERAL DESCRIPTION**

The KSSD Series Sampling Device is designed for gauging the height of liquid levels, measuring the depth of water bottoms, taking temperature, and taking sample of liquids held in storage tank, without relieving pressure within the tank.

It avoids the loss of valuable vapors, and exposing the gauger to excessive fumes.

Quick opening valve unit is opened and closed simply by moving a lever through a 90deg C arc.

A by-pass is provided to equalize in the tank and sampling chamber unit, if this should be necessary for easy opening.

The window in the top cover of the gauging unit can be provided with an inside wiper, to insure clear vision of the gauge taper, and to permit the taking of accurate reading.

Installation

1. Mount the KSSD Series Sampling Device on 4" or 8" flange roof nozzle.
2. Attach the gauging bob or sampling bottle to the swivel snap inside the sampling chamber unit.
3. Check the distance from the bottom of the bob to a point above the snap on the tape to make certain a correct reading is obtained.

Operation

KSSD Series Sampling Unit can be used for :

- 1) Gauging the depth of the product.
- 2) Taking a sample at any level.
- 3) Measuring the depth of water bottom.
- 4) Measuring the product temperature.

SAMPLING DEVICES

KSSD

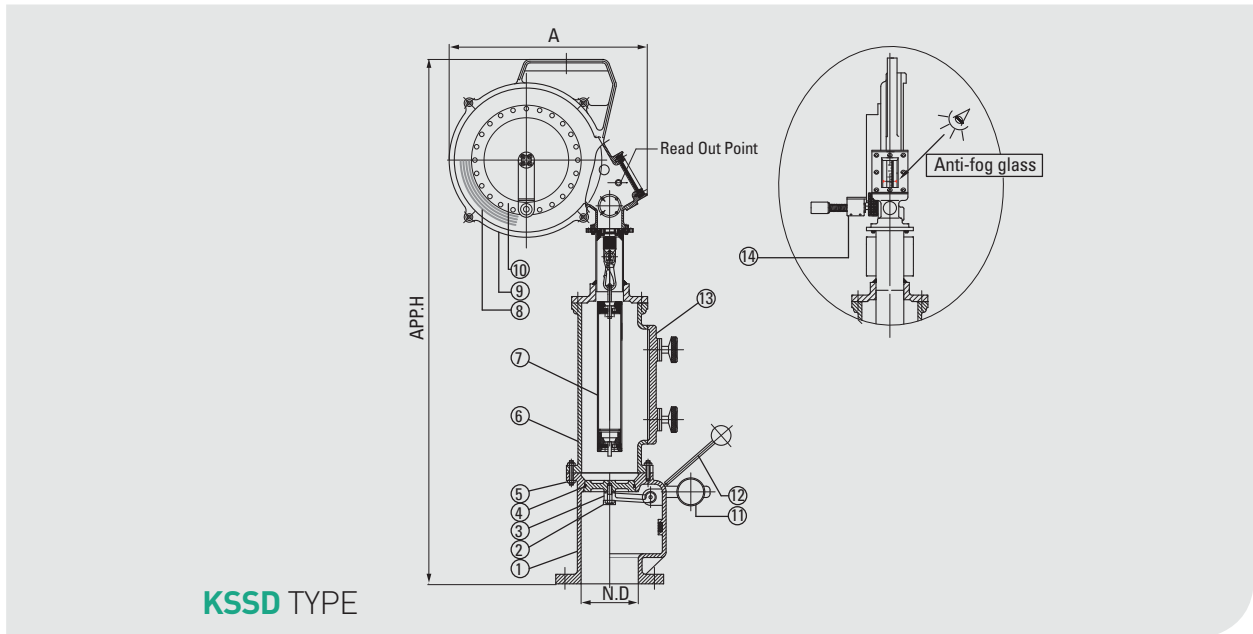

Dimension Table

Unit = mm

SIZE	4"	6"	8"	10"	12"
N.D	80	100	150	200	250
A	346	346	346	346	346
APP.H	1330	1335	1340	1345	1350

Materials of Construction

ITEM NO	COMPONENT	BODY	ALUMINIUM	C.S	SS304	SS316
		TRIM	SS304	SS304	SS304	SS316
1	UPPER BODY		B26-319.F	A216-WCB	A351-CF8	A351-CF8M
2	PALLET ARM STOPPER		TEFLON	TEFLON	TEFLON	TEFLON
3	PALLET ARM		SS304	SS304	SS304	SS304
4	PALLET		A5052	A5052	A5052	A5052
5	STUD BOLT		SS304	SS304	SS304	SS304
6	UPPER BODY		B26-319.F	A216-WCB	A351-CF8	A351-CF8M
7	SAMPLING BOTTLE		SS304	SS304	SS304	SS304
8	SCALE		NYLON + PTFE COAT	NYLON + PTFE COAT	NYLON + PTFE COAT	NYLON + PTFE COAT
9	SCALE ROLLER BODY		B26-356-T6	B26-356-T6	B26-356-T6	B26-356-T6
10	SCALE ROLLER		B26-356-T6	B26-356-T6	B26-356-T6	B26-356-T6
11	COUNTER WEIGHT		A283-C	A283-C	A283-C	A283-C
12	PALLET OPERATING HANDLE		SS304	SS304	SS304	SS304
13	PALLET WEIGHT		B26-319.F	A216-WCB	A351-CF8	A351-CF8M
14	HANDLE ASS'Y		SS304	SS304	SS304	SS304