

EMERGENCY PRESSURE RELIEF VENT COVER

KSEP

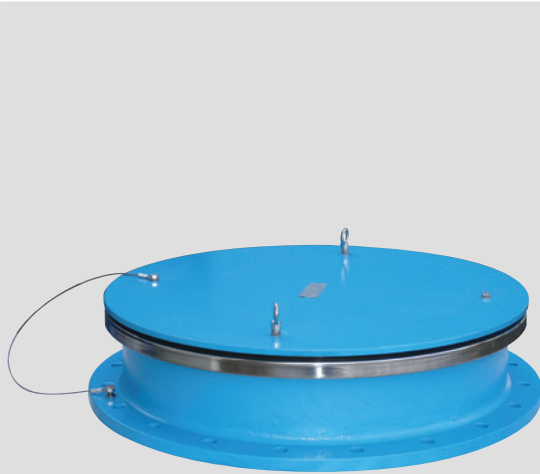

According to API 2000 Code :

The series KSEP is designed to provide emergency pressure relief for storage tanks when exposed to overpressures that are not handled by standard tank vents.

These vents provide the capacity to meet API standard 2000 for emergency venting due to fire exposure when properly sized.

These covers also provide quick easy access for tank inspection and maintenance.

Vent Operation

The KSEP emergency pressure relief vent provides pressure relief only.

Vacuum relief must be supplied by normal venting devices, or use our KSEV emergency pressure and vacuum relief vent covers.

When excessive pressure builds within the storage tank the KSEP series emergency pressure relief vent begin to open at a predetermined set pressure relieving excessive pressure.

When the overpressure has dissipated the cover reseal onto the base.

Construction

The series KSEP is available in several materials that are corrosion resistant to most petroleum product applications.

See Standard material of construction table for available material.

Predetermined setting range is from a minimum of 50mm W.C to a maximum of 700mmW.C

Sizes are 400, 450, 500 and 600mm with flange drilling according to ANSI 150lb or API650.

Section 4.1

EMERGENCY PRESSURE RELIEF VENT COVER

KSEP

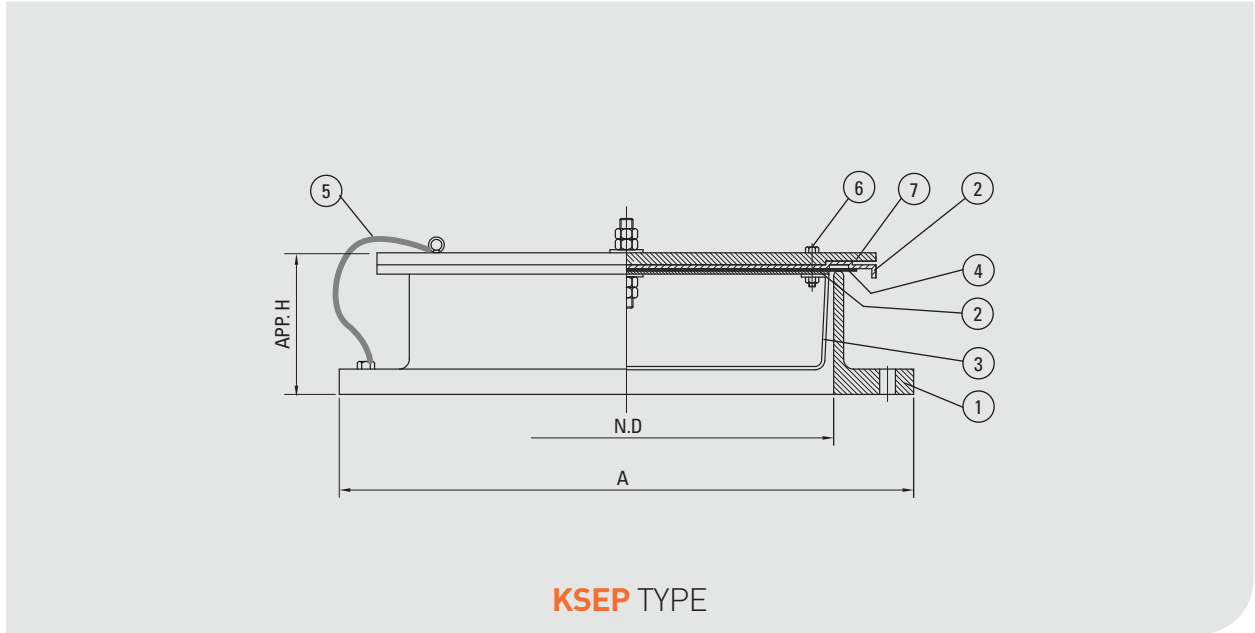

Dimension Table

Unit = mm

		16"	18"	20"	24"
N.D		400	450	500	600
A	API 650	597	635	660	762
	ANSI 150#	597	635	700	815
APP.H	MIN.	115	115	115	115
	MAX.	150	165	180	200

Materials of Construction

ITEM NO	COMPONENT	BODY	ALUMINIUM	C.S	SS304	SS316
		TRIM	SS304	SS304	SS304	SS316L
1	BODY		B26-319.F	A216-WCB	A351-CF8	A351-CF8M
2	COVER & PLATE		SS304	SS304	SS304	SS316L
3	GUIDE		SS304	SS304	SS304	SS316L
4	DIAPHRAGM		TEFLON			
5	EARTH WIRE		SS304	SS304	SS304	SS304
6	HEX BOLT/NUT		SS304	SS304	SS304	SS304
7	LOADING W/T		C.S OR SS			